



MICRO LIMIT SWITCH



FEATURES

- ☑ Weatherproof limit switch.
- ☑ Compact & Light Weight Design
- ☑ Open / Close Indication show in any direction.
- ☑ No extra attachment require for Indicator Dome inbuilt with Transparent cover.
- ☑ Every adjustable serrated cam for fast & Fine switch adjustment & Also helpful for fine adjusting of feedback setting.
- ☑ Cable entries with various connection availability M20 & 1/2" NPT.
- ☑ Additional mounting available as the UNC series.
- ☑ A Stainless steel bracket is available as an option.
- ☑ Temperature range - 20°C to + 80°C

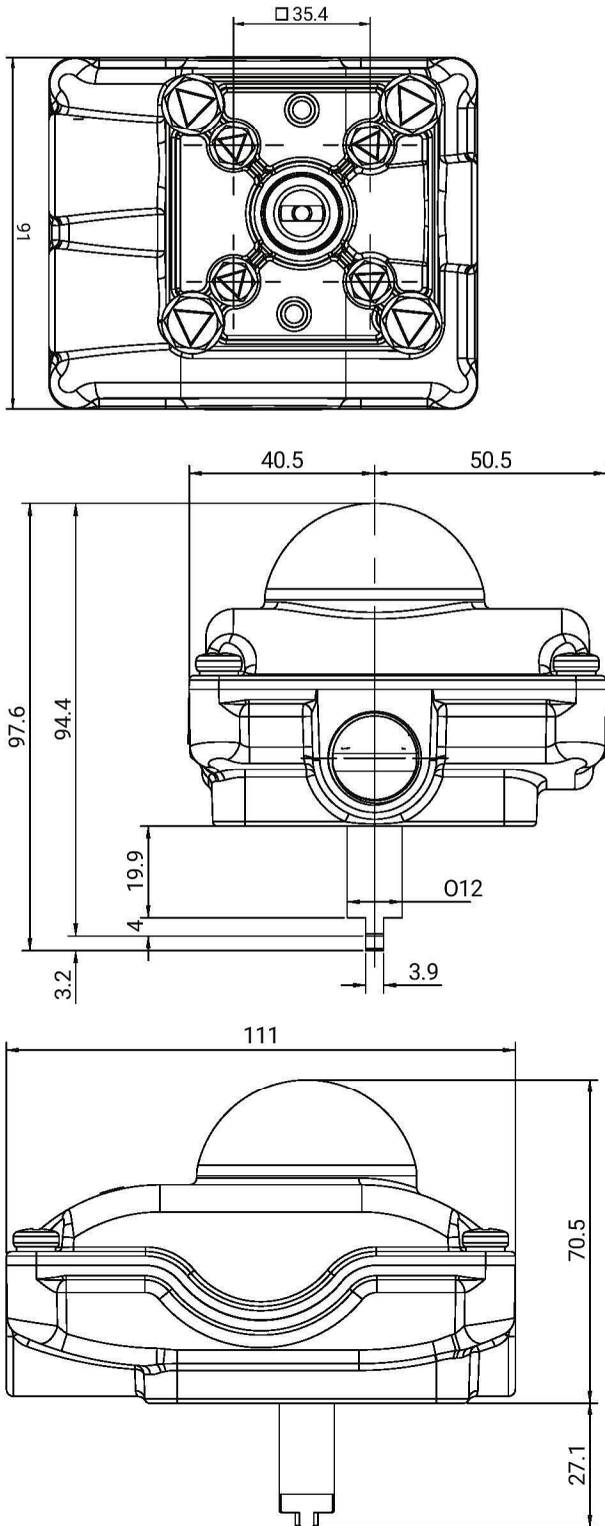

WIRING DIAGRAM

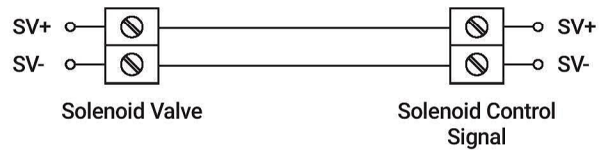
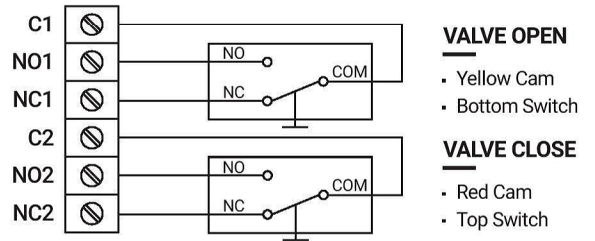

INDICATOR

- ☑ The two piece unique indicator, ensures a life long visibility



Standard Indicator Color Red & Yellow

LIMIT SWITCH IDENTIFICATION CHART

G W 1 2 A

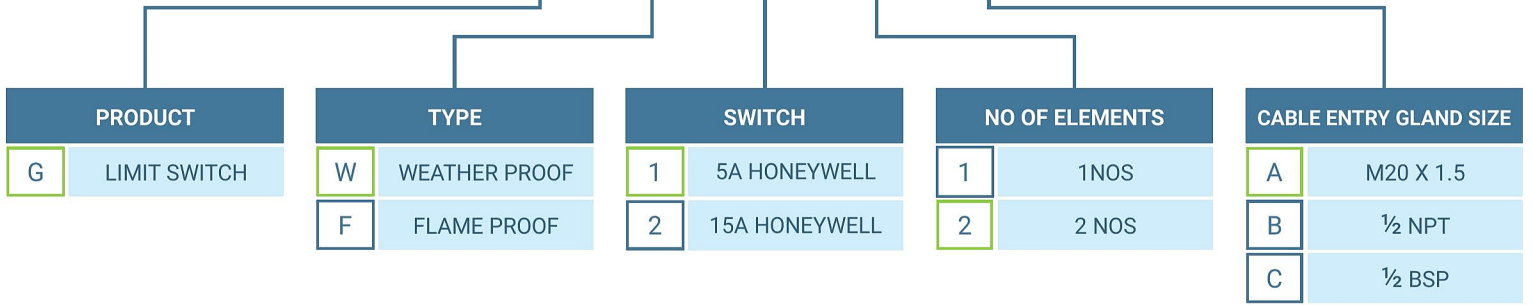

GW12A
 MICRO LIMIT SWITCH WEATHER PROOF (M20X1.5-3 NOS)(5AMP HONEYWELL)(2NO & 2NC)